



Easy Mat Repair Kit

Description

The Easy Mat repair kit is for repairing heating cable that is damaged during installation of the Easy Mat. The kit includes splices and heatshrink insulation to repair one damaged section. If you have damaged more than one section than the entire mat needs to be replaced.

Tools Required

- Wire Stripers 12-26 A WG
- Splice crimper #2 - #6
- Gloves
- Scissors
- Heat gun (1000 DF air temp with heat reflector)
- Multimeter (capable of 200K ohms)

Optional Tile Removal Tools

- Grout removal tool
- Hammer

Kit Contents

Item A	4	Splice connectors
Item B	4	Conductor heatshrink tubing
Item C	1	Overall heatshrink tubing w/ glue
Item D	1	Black 16 A WG
Item E	1	Green 16 A WG

Installation Instructions

1. Turn off the power to the Easy Mat floor warming system at the circuit breaker before starting any repair work.



2. Disconnect the Easy Mat cold leads, power wires and floor sensor leads from the Thermostat. This provides additional safety and allows for the testing required in later steps.
3. If the damaged section has not been installed in mortar, proceed to Step 7. Remove the tile above the damaged section by removing the grout with a removal tool, being careful not to further damage the heating cable. Do not use a knife or chisel.

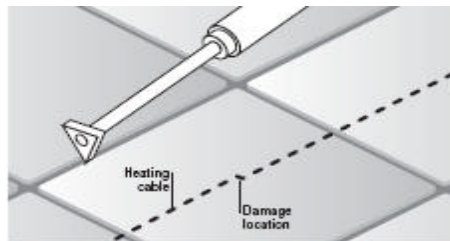

4. Once the grout is removed, carefully break away the tile using a hammer.



5. Remove any broken tile and vacuum other debris from the exposed surface to locate the damaged heating cable section.

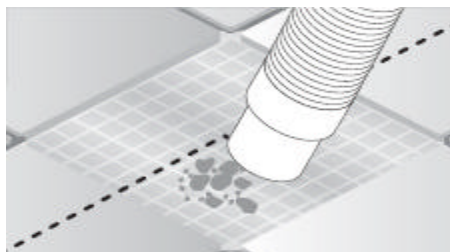

6. To expose the damaged section, break the mortar away from the heating cable with the hammer, making sure not to damage the cable.

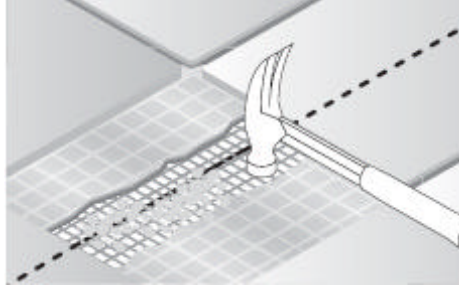

7. Remove sufficient mortar to expose 4-5 inches of heating cable on either side of the damage. Using scissors cut the tin foil from the cable to provide room to install the splice.

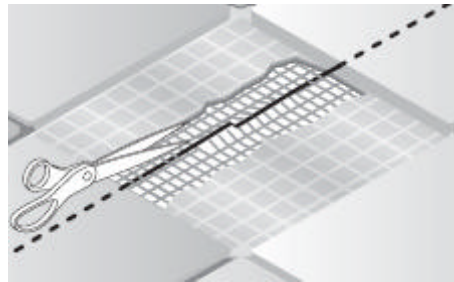

8. Remove at least 3 inches, and up to 5 inches of heating cable including the damaged section leaving two protruding ends of heating cable. If more than 5 inches of cable has been damaged, the mat must be replaced.

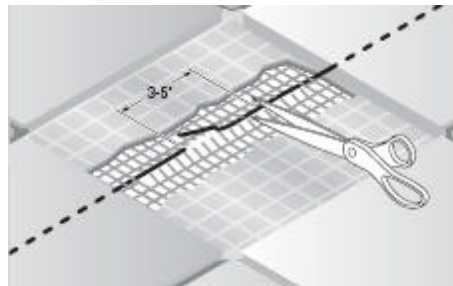

9. Remove the damaged section.

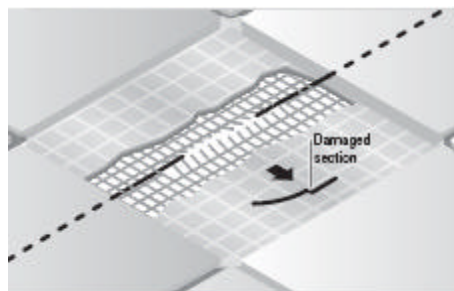

10. Using the 12 AWG opening on the wire strippers carefully score the outer jacket, 2 inches from the end of both exposed heating cable ends.

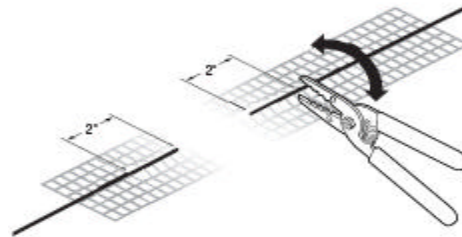

11. Flex the cable to break the insulation at the score.

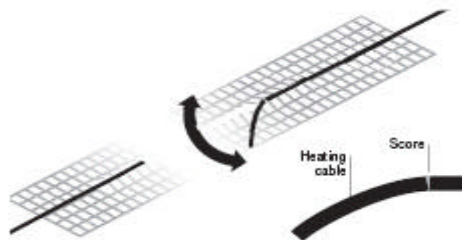

12. Using the high setting on the heat gun, heat the jacket to loosen the insulation.



13. While the cable is still hot, use strippers to remove the outer jacket and foil layer to expose the heating elements.

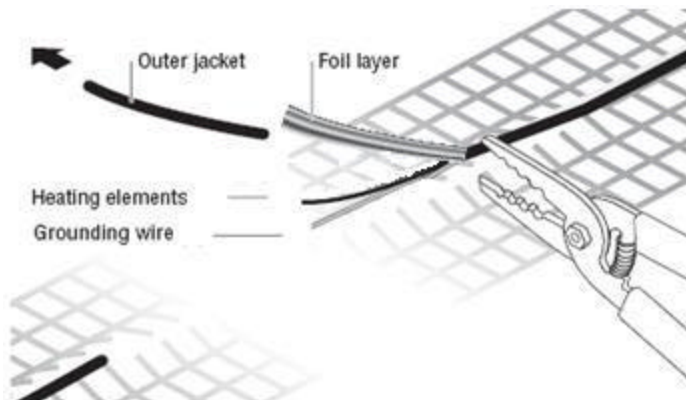

14. Twist the ground wire together



15. Heat only 1/2" of the insulated end of the heating element to soften.



16. While the wire is still hot, use the wire strippers to remove 1/4" of the outer insulation to expose the heating element.

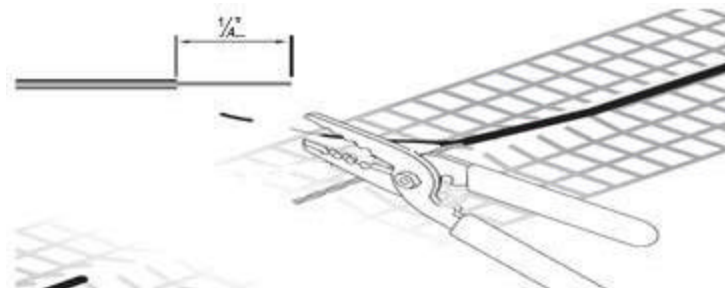

17. Repeat steps 10-16 for the other exposed heating cable end.

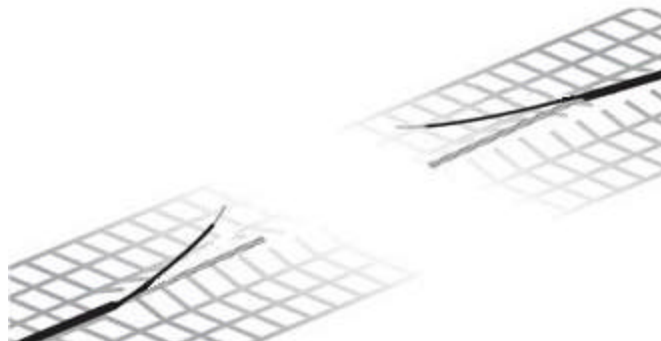

18. Test both ends of the heating cable using this insulation resistance test to verify there is not further damage to the heating cable.
1. Connect the ground wire to the black lead on the multimeter, connect the heating element wire to the red lead on the multimeter. .
 2. Make sure the meter reads 'Open' or 'OL'

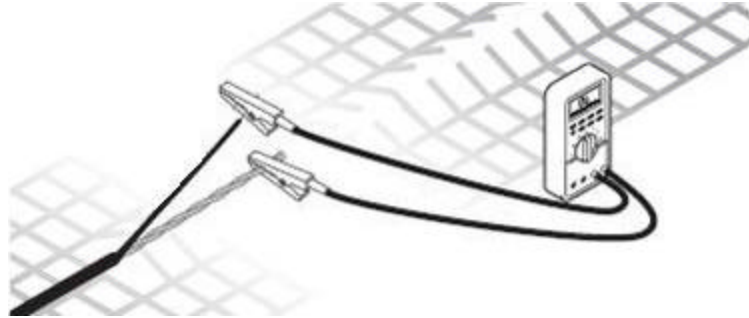

19. Cut jumper wires (item D and E) to length allowing for 1/2" overlap on each end as shown.

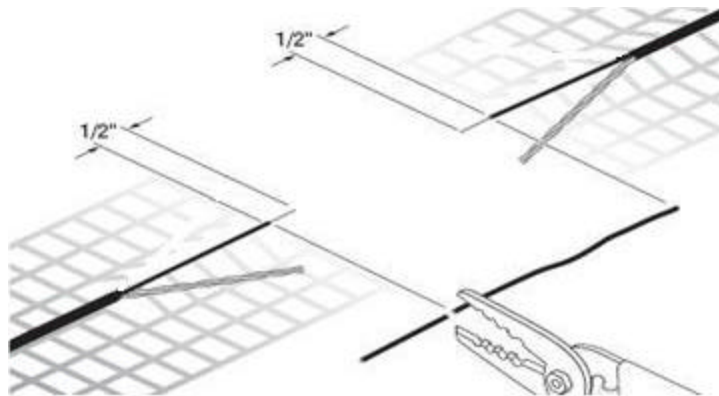

20. Strip 1/4" of insulation off both ends of each jumper wire.

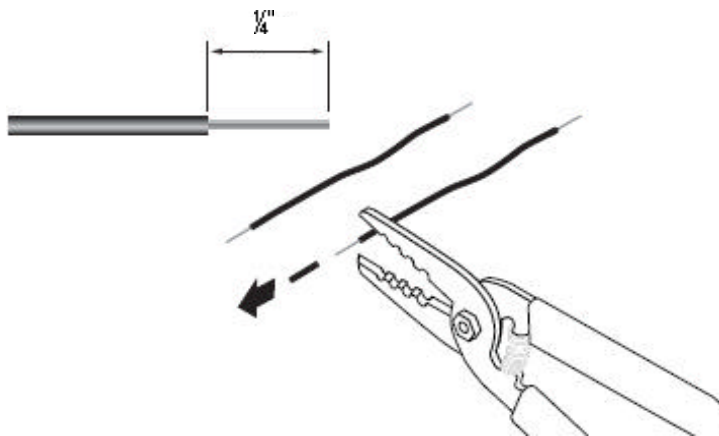

21. Slide splice connector onto one end of wire and crimp.
Insert jumper wire into the splice connector and crimp.

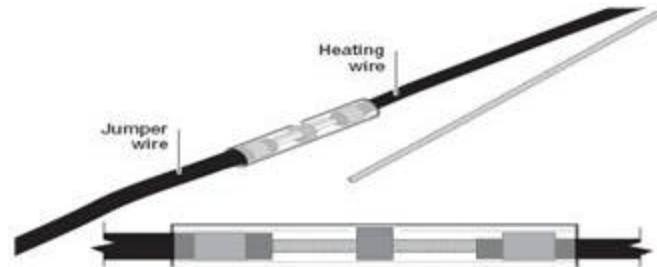

22. Slide two heat-shrinkable tubes onto each jumper wire.



23. Slide the Heat-Shrinkable tubing over all the wires, so that it can later be used to insulate the entire repair area (item C).

24. Slide the splice connector onto the heating wire and crimp.



25. Centre the 4 black heat-shrinkable tubes over the installed splice connectors, and shrink in place using the heat gun.

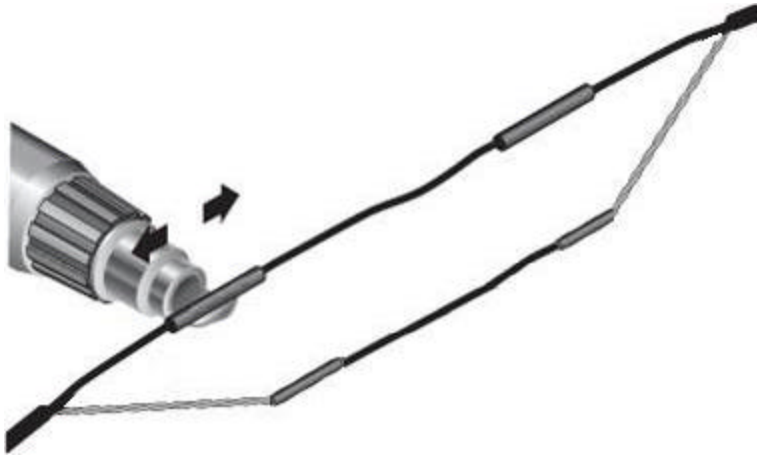

26. Slide the overall heat-shrinkable tubing with glue over the entire repair area and shrink in place using the heat gun.

Testing Procedure

1. Set your multimeter to the 400 ohm range
2. Connect the multimeter leads to the black (or red) and white cold lead wires.
3. Compare this resistance reading to the resistance specified on the Easy Mat label. The value should be within +/- 10%.